

ercol  
for John Lewis

ercol Shalstone Desk nt  
Stock Number: 816 29101

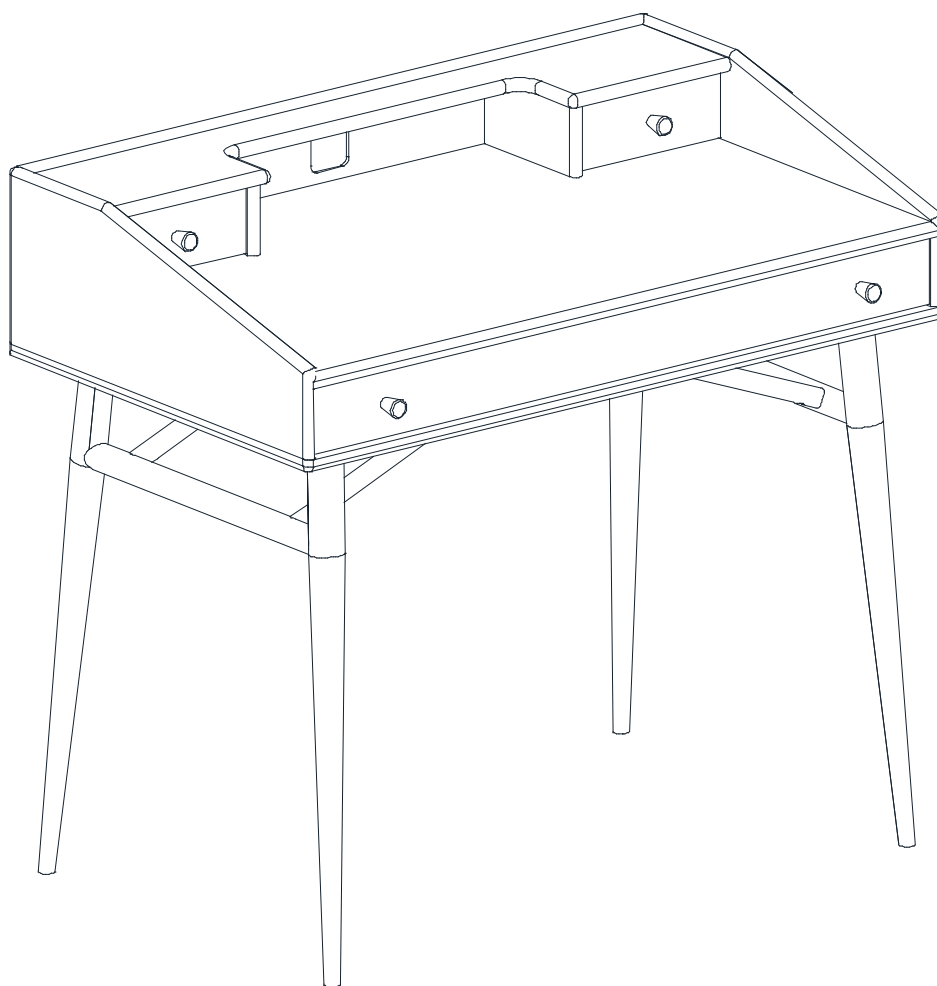

H87 W100 D60cm

Thank you for purchasing the ercol Shalstone Desk. Please read the instructions and warnings carefully before use, to ensure safe and satisfactory operation of this product.

At John Lewis, we are committed to making great products possible.

From our in-house Design Team, to our Buyers, we work together to bring great design to life.

Our expert Product Technologists work collaboratively with our buyers and suppliers to assure the legality, safety and quality of the product we sell.

We are all committed to designing and developing products to the highest industry standards.

We hope you are happy with your ercol product and welcome any feedback or comments you may have.

The John Lewis Team

### Tools Required

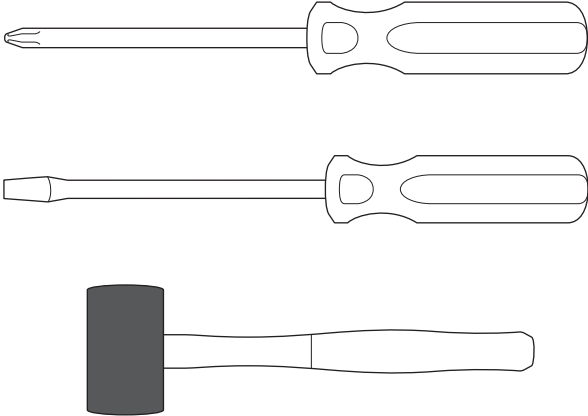

**Time to assemble**  
1 hour

**People to assemble**

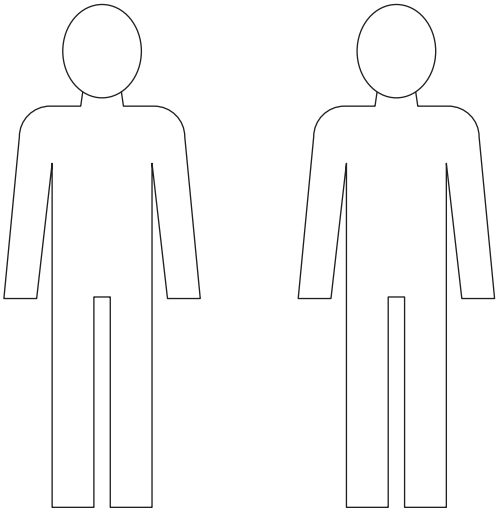

# Important safety information

## Warnings

- ⚠ The product should only be used on firm, level ground.
- ⚠ Keep small parts out of reach of children.
- ⚠ Ensure the product is fully assembled as illustrated before use.

## Do's

- ✓ Check the pack and make sure you have all the parts listed.
- ✓ Check all screws or bolts are tightened and inspect regularly.
- ✓ Make sure the legs remain in contact with the ground at all times.

## Dont's

- ✗ Do not over tighten screws or bolts.
- ✗ Do not stand on the product.
- ✗ Do not use power tools to construct as overtightening and panel failure may occur.

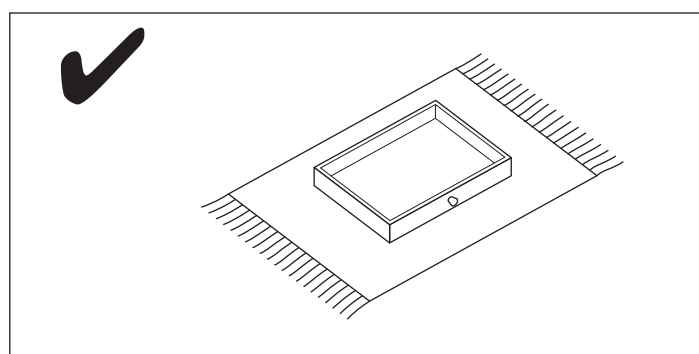
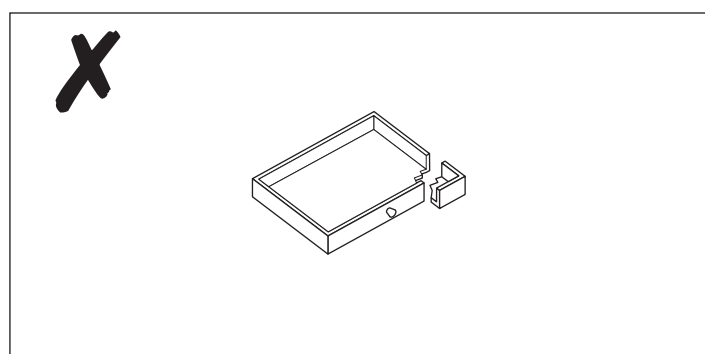
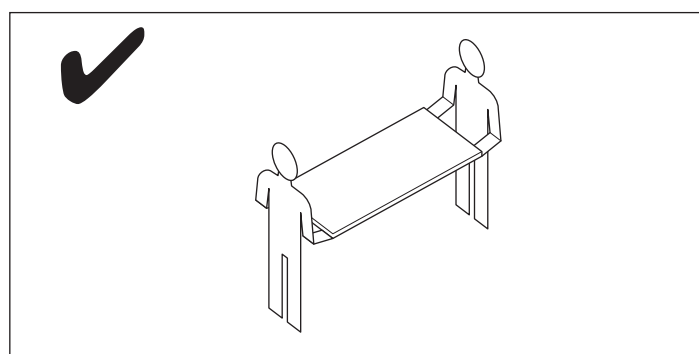
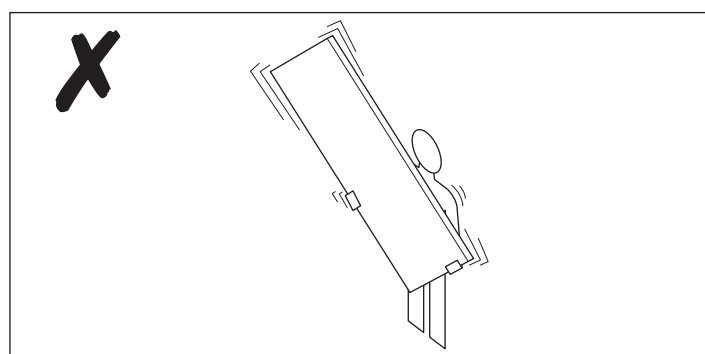
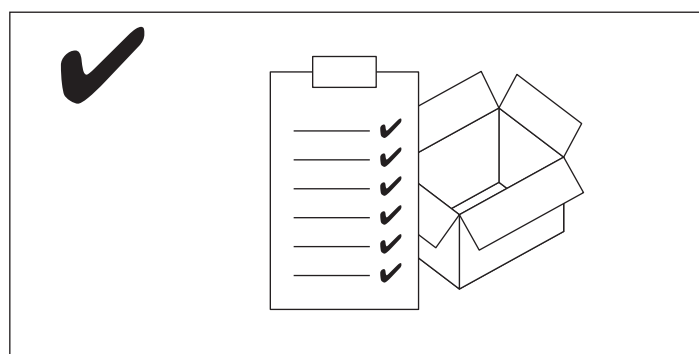
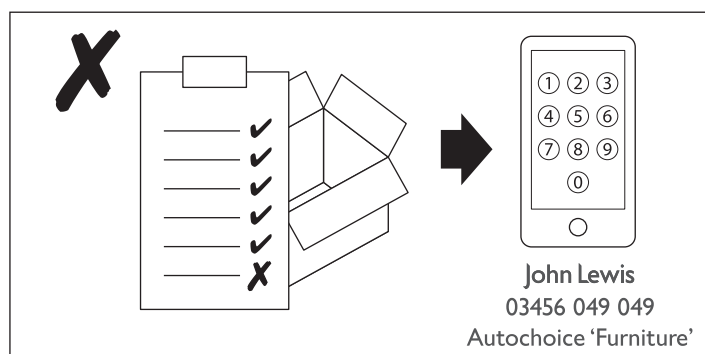

# Your Desk

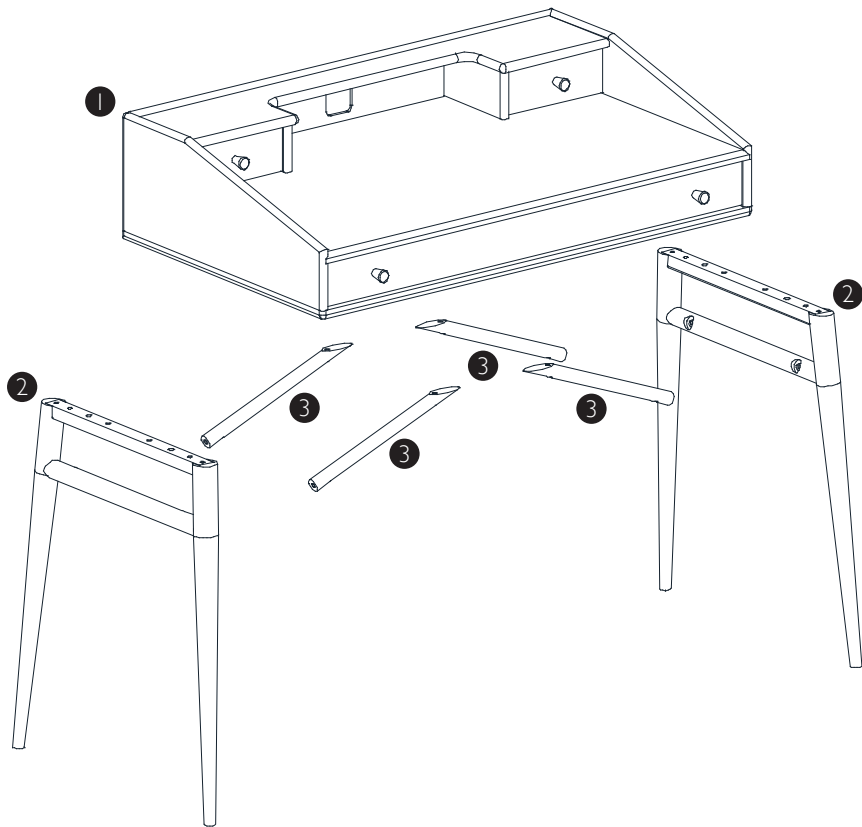

Ref	Description	Dimensions	Qty
①	Top Module	245mm x 600mm x 1000mm	1
②	Leg Frame	68mm x 496mm x 673mm	2
③	Support Rail	25mm x 25mm x 358mm	4

## Internal dimensions

Stock number: 816 29101



Small drawer internal size: H7 W19 D14cm

Large drawer internal size: H7 W94 D40cm

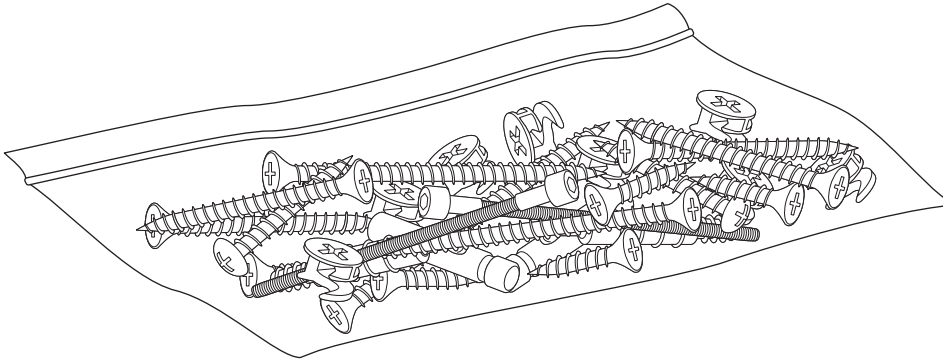
# Fixtures and fittings

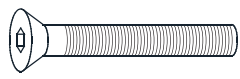
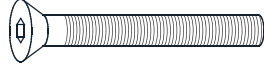

Fixtures and fittings  
supplied (actual size)

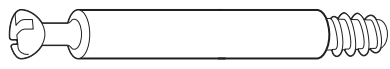
Ref	Description	Dimensions	Qty	mm
A	Allen Head Bolt	6mm x 30mm	4	
B	Allen Head Bolt	6mm x 35mm	8	
C	Cam Head	15mm x 13mm	4	
D	Grub Screw	8mm x 8mm	4	
E	Cam Rod	7mm x 50mm	4	

Fixtures and fittings  
supplied (not actual size)

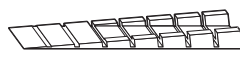
Ref	Description	Dimensions	Qty	
F	Allen Key M4		1	
G	Wedge		1	

# Product Assembly

Shalstone Desk  
816 29101

## Step 1

Parts, fittings and tools

**E** **2**

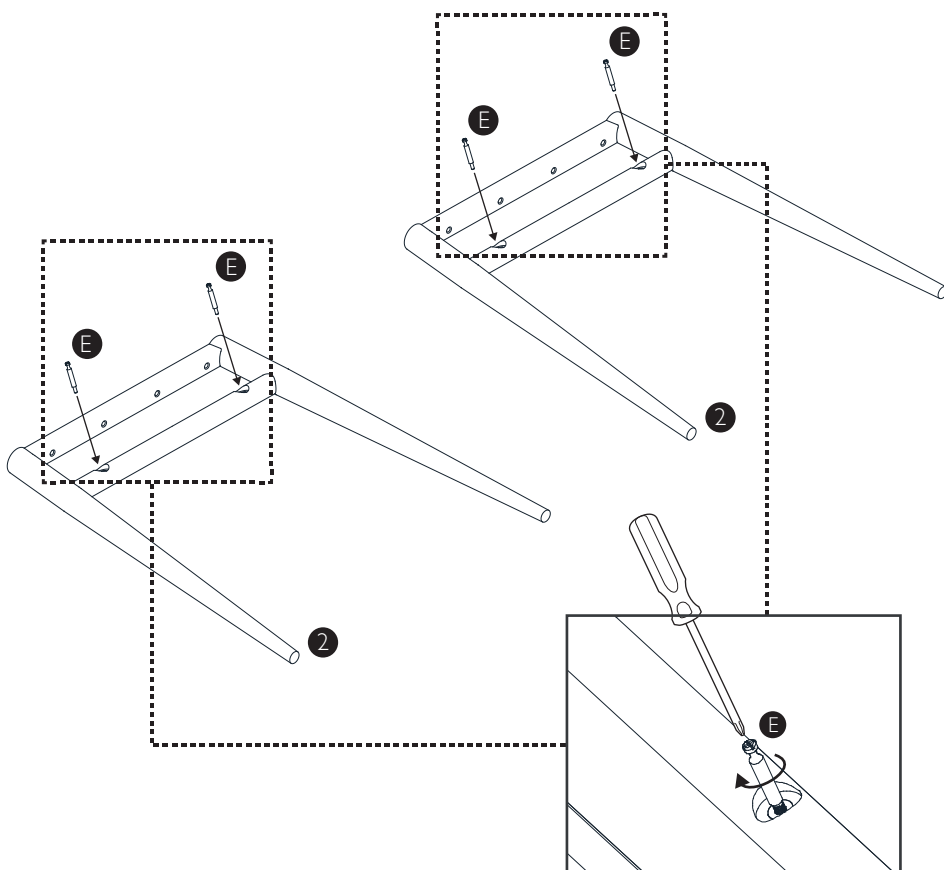
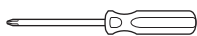

## Step 2

Parts, fittings and tools

**C** **3**

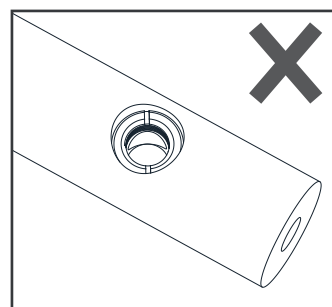
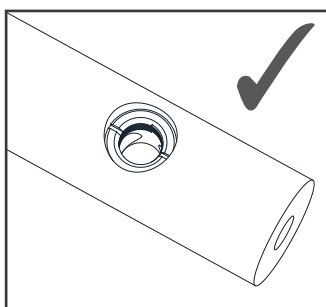
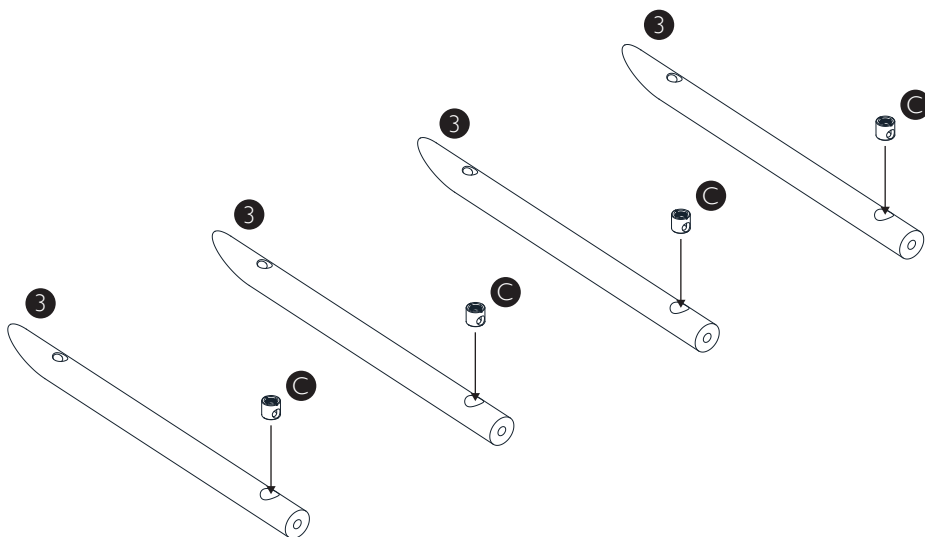

## Step 3

Parts, fittings and tools

2 3

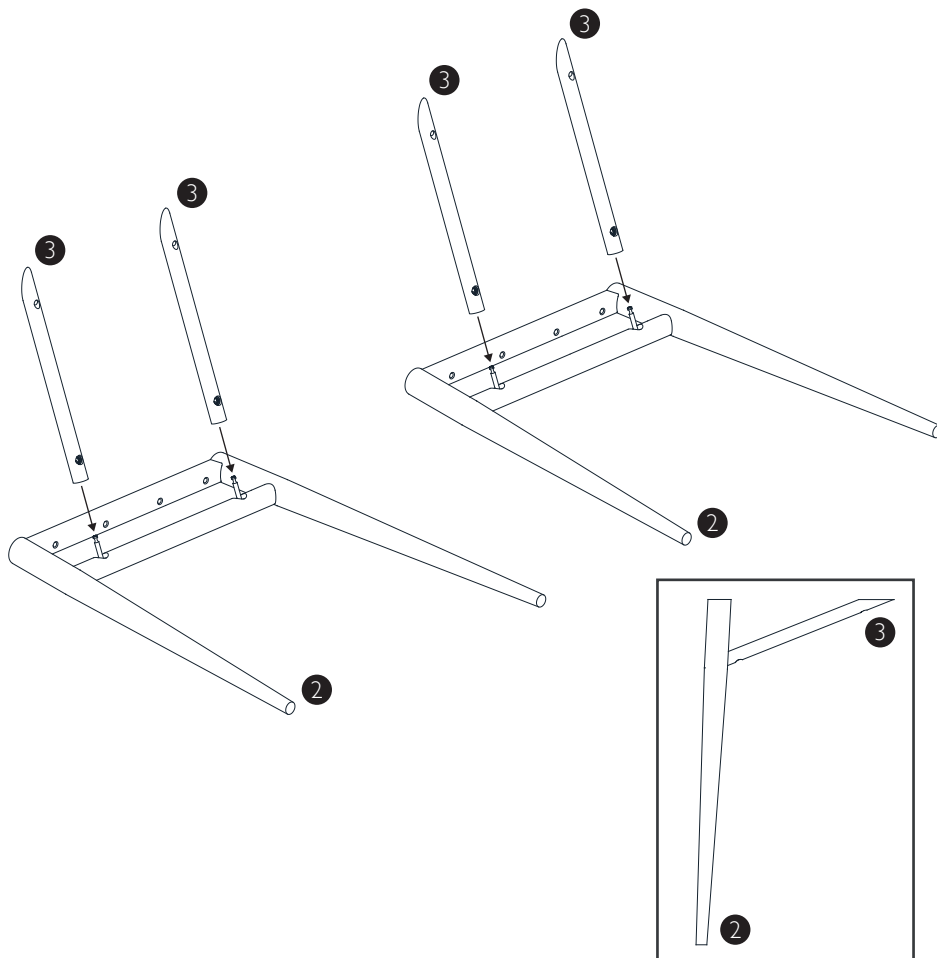

## Step 4

Parts, fittings and tools

D

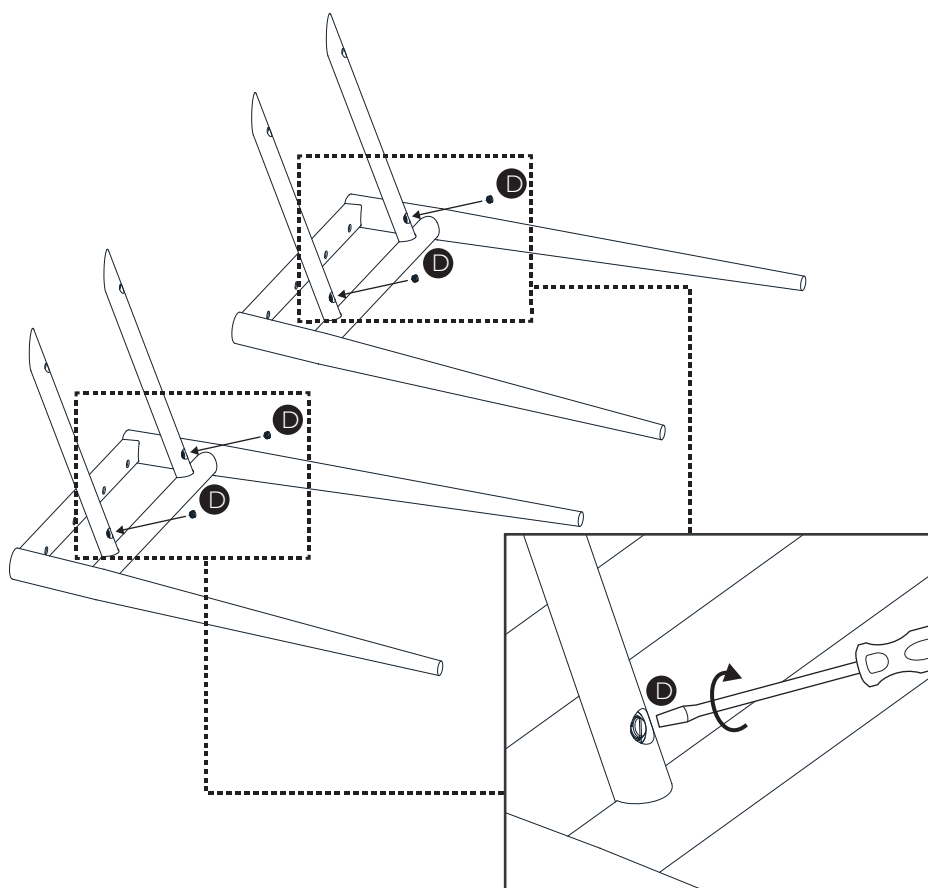

# Step 5

Parts, fittings and tools

- I
- A
- B
- F

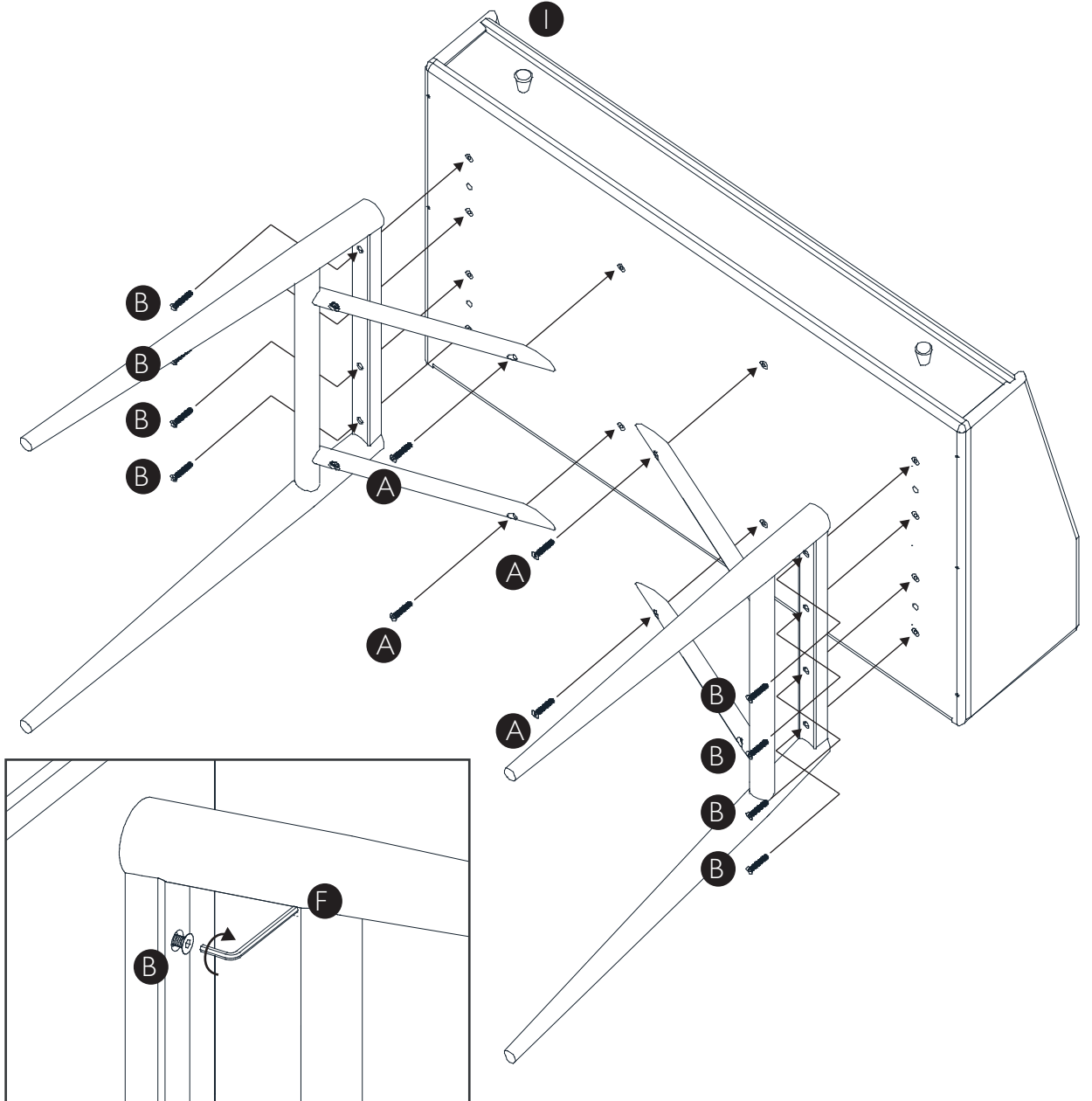



## Step 6

Parts, fittings and tools

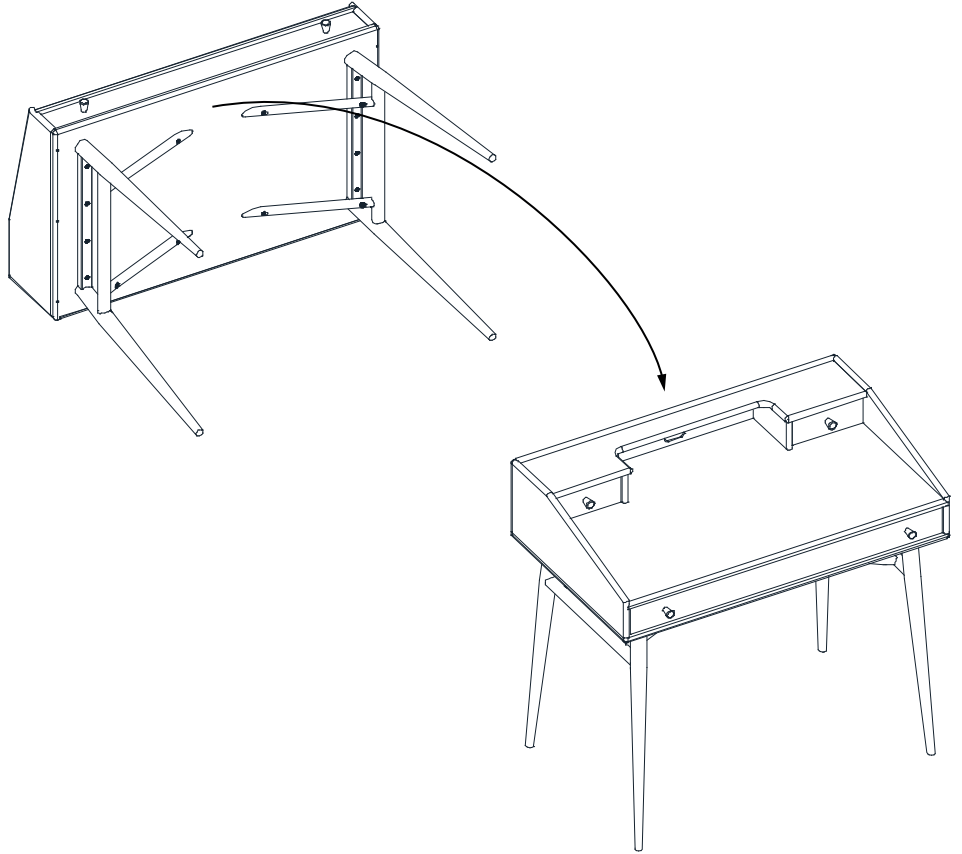

## Step 7

Parts, fittings and tools



If the desk is not level on your floor use the wedge (G) provided, and snap it off so that it does not protrude out from the cabinet's leg, you can also snap it lengthways if desired.

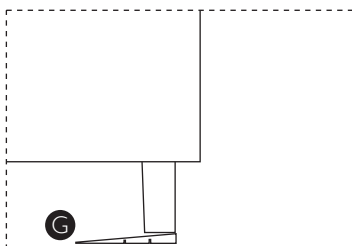
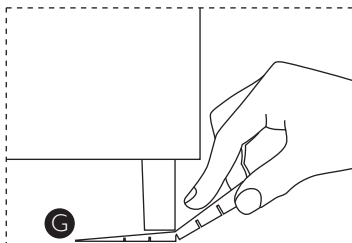
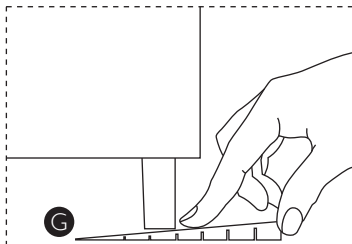

# Wall Fixings Assembly

Parts, fittings and tools

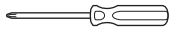

**1** Place your product in the final position. Loosen the screws on the metal brackets just enough so that the slotted bracket can be extended to meet the wall.

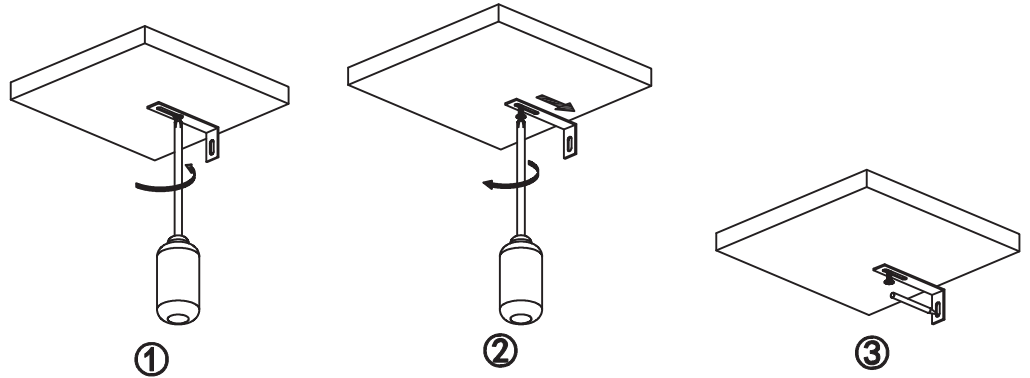

**2** Then re-secure the screws.

**3** Mark the wall for drilling through the hole in the short face of the bracket.

Then remove the unit from the wall so that the marked holes can be drilled.

Ensure you use an appropriate fixing type for your wall (see page 5). Then return the unit to position.

**4** Secure the unit to the wall fixings with own screws through the brackets.

**5** Finally add the extra securing screws provided to the holes in the long faces of the brackets.

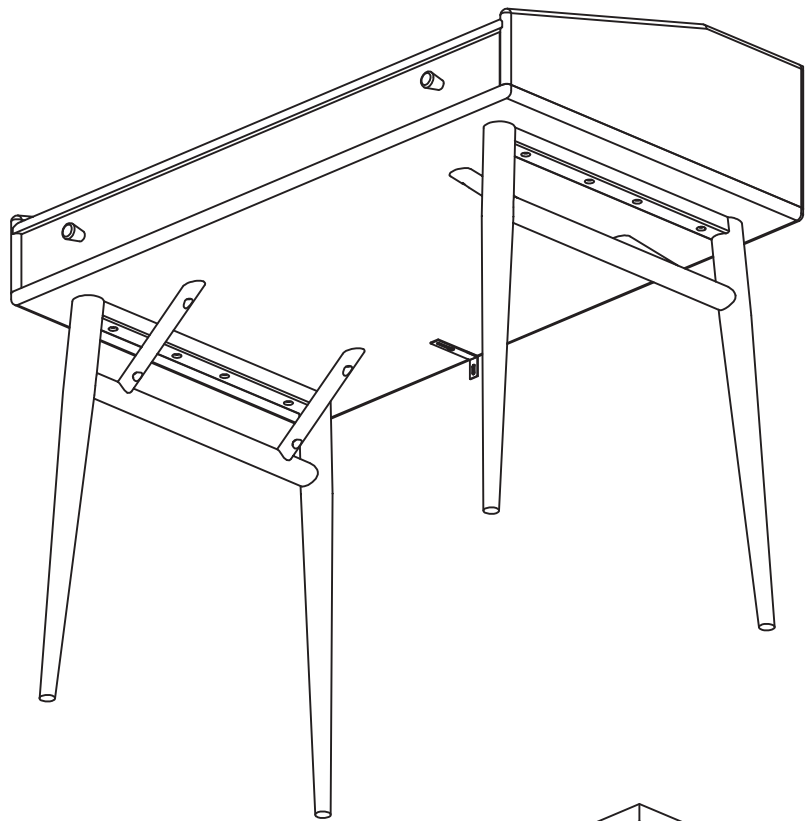

## Warning

Serious or fatal crushing injuries can occur from furniture tipping over.

To prevent this furniture tipping over it must be permanently fixed to the wall.

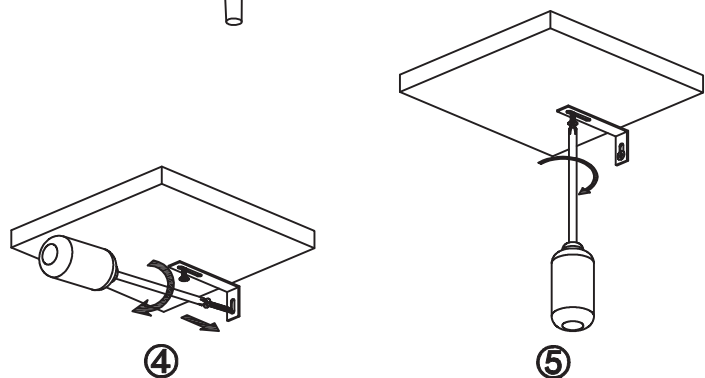

Wall attached item only.

## A guide to wall mounting and fixings



### Warning

Serious or fatal crushing injuries can occur from furniture tipping over.

To prevent this furniture from tipping over it must be permanently fixed to the wall.

Wall fixing screws are not included, since different wall materials require different types of screws/ fixings. Please ensure you use the correct screws / fixings for your type of walls and seek professional advice if you are not sure.

Failure of the product due to incorrect fixings is the responsibility of the installer.

**Important:** When drilling into the walls always check that there are no hidden wires or pipes etc.

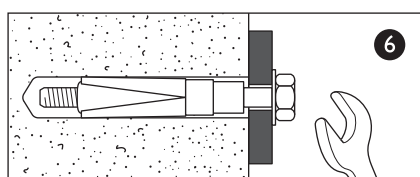
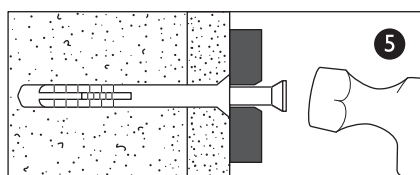
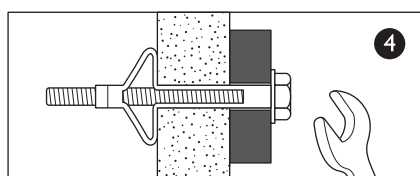
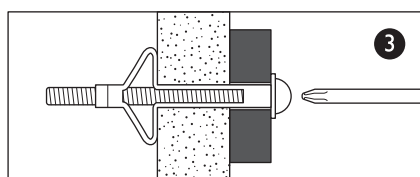
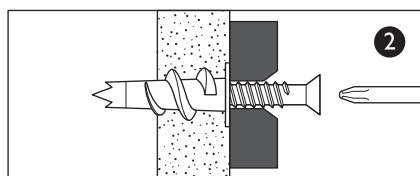
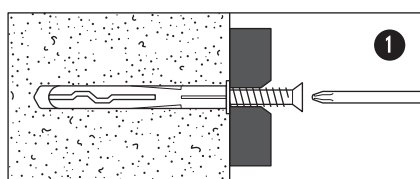

### Types of walls

You can use one of the following types of wall plug if your walls are made of brick, breezeblock, concrete, stone or wood.

#### 1. General Purpose wall plug

Generally aerated blocks should not be used to support heavy loads, use a specialist fitting in this case. For light loads, general - purpose wall plugs can be used.

#### 2. Plasterboard wall plug

For use when attaching light loads on to plasterboard partitions.

#### 3. Cavity Fixing wall plug

For use with plasterboard partitions or hollow wooden doors.

#### 4. Cavity Fixing - Heavy Duty wall plug

For use when fitting or supporting heavy loads such as shelving, wall cabinets and coat racks.

#### 5. Hammer Fixing wall plug

For use with walls stuck with plasterboard. The hammer fixing allows it to be fixed to the wall rather than the plasterboard. Always check the fixing is secure to the retaining wall.

#### 6. Shield Anchor wall plug - Heavy loads

For use with heavier loads such as TV and Hi-Fi speakers and satellite dishes etc.



**Safety:** Periodically check all fittings and wall fixings to ensure they have not come loose and retighten as necessary.

## Safety Instructions

### General warnings

Never drag furniture when moving it, always lift it. Periodically check all fixings to ensure none have come loose and re-tighten where necessary. Please take care when handling or moving the furniture as careless handling may cause damage or injury. Furniture can be dangerous if incorrectly installed. Assembly should be carried out by a competent person. No liability will be accepted for damage or injury caused by incorrectly installed or assembled furniture.

### Specific warnings for heavy items

It is recommended that before moving heavy objects to a new location they are completely dis-assembled to avoid personal injury or damage to the furniture. Please be careful to retain all fittings when doing this. (For fully or partial assemble items ).

## Safety Instructions

Never drag furniture when moving it, always lift it. Please take care when handling or moving the furniture as careless handling may cause damage or injury. No liability will be accepted for damage or injury caused by incorrectly installed furniture.

### Storage units over 600mm

Installation shall be carried out exactly according to the manufacturer's instructions – otherwise a safety risk can occur if incorrectly installed; a warning shall be given to the consumer to notify them of related risks.

**WARNING** In order to prevent overturning this product must be used with the wall attachment device provided.

### Chair specific warnings

Never tilt the chair. Ensure the chair is always placed firmly on the ground. Regularly check leg attachment and retighten screws as necessary. Do not use chair if legs are unstable. Please check fixings and tighten as required.

### Stool/Barchair specific warnings

Never tilt the chair. Ensure the chair is always placed firmly on the ground.

### Important safety note:

**Do Not:** Use the stool as a ladder. Climb on the stool. Stand on the foot-rest of the stool, as this could lead to the stool becoming unbalanced and overturning.

### Warnings specifically for any product containing glass

If the glass is chipped or broken stop using the product and consult the manufacturer or supplier.

### WARNING:

- a) Do not place very hot or very cold items directly on glass surfaces.
- b) Do not sit or stand on glass surfaces.
- c) Do not strike the glass with hard or pointed items, or use the glass as a chopping surface.
- d) Do not use washing powders or any other substances containing abrasives, as these may scratch the glass.

### Additional Requirements for tables

**Handle with care!** A damaged edge or scratched surface can in rare cases cause the glass to fail unexpectedly into many small pieces. Glass is most vulnerable when struck from the side.

## Care Instructions

### Wood Furniture

Wood displays different grain patterns depending on which way they are cut -for example, the 'medullary ray' which can appear on oak furniture is a mark of good quality timber - these are just characteristics of the natural beauty of the wood. Some furniture is also deliberately aged and rustic.

Wood veneers also allow distinctive patterns to be created on flat surfaces, such as table tops and drawer fronts by the way the slivers are arranged.

All timber surfaces will change colour and mellow over time. New furniture will initially vary in shade from items that have been previously purchased.

### How to care for your wood furniture

Furniture with a hard lacquer, wax polish or painted surface should be dusted with a dry cloth.

Waxed furniture will need to be given a coat of beeswax a couple of times a year to help maintain its lustre.

Spray polishes are best avoided as they contain silicones which may spoil the furniture's surface by building up over time.

Make sure all surfaces are protected from heat and liquids by mats and coasters. Wipe up spills immediately and ensure that a mat or pad is placed under paper if you are writing.

Extendable dining tables should be left extended for the first few months to avoid an uneven appearance. Likewise, lamps and ornaments should also be moved regularly.

Our furniture will endure most temperatures in the home but it is best to avoid placing furniture next to heat sources such as radiators or fires. Be particularly careful with solid wood as the lack of humidity caused by central heating can cause damage such as warping

### Glass and acrylic furniture

Use glass cleaner or soapy water for cleaning, do not use anything abrasive as this may damage the surface of the product.

Protect surfaces from scratches and marks by using mats and coasters.

### Metal and leather

Protect leather from spillage, sunlight and heat. A slightly damp cloth is the best cleaning agent for both materials.

Do not use any abrasive cleaner or harsh detergent as this can damage the surface. Care for the leather with leather conditioner. We recommend applying leather conditioner before using the furniture for the first time.

Avoid spilling or dropping crumbs of food with a high fat content on the surface as this can permanently mark the leather.

**Your feedback is very important to us and we would love to hear your comments on your new furniture. Please visit our website to leave a review. Thank you.**

PLEASE KEEP THESE INSTRUCTIONS FOR FUTURE REFERENCE

John Lewis Partnership  
1 Drummond Gate  
Pimlico  
London  
SW1V 2QQ  
johnlewis.com