

ercol

3506 HUGHENDEN

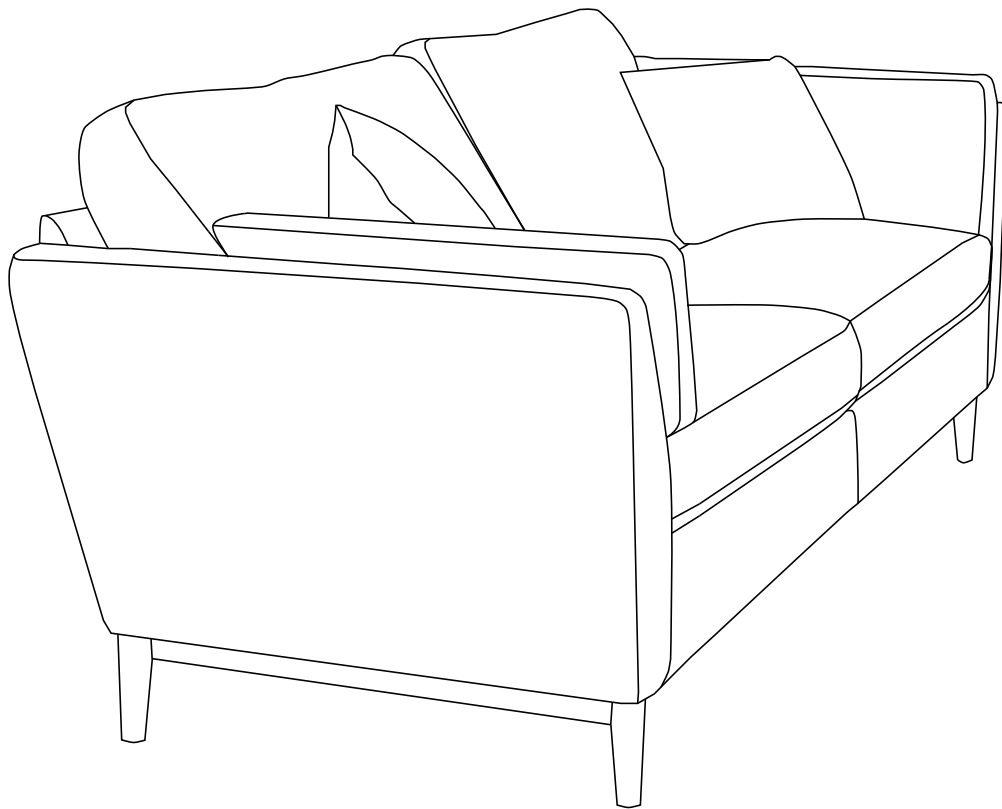

Thank you for purchasing this Hughenden sofa. Please read these instructions carefully before fitting the wooden legs to your new furniture. It is essential that the legs are correctly fitted otherwise damage could occur.

PREPARATION

This is a two person operation



Tools you will need



Time

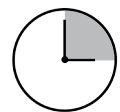

This item is heavy, take care to avoid personal injury and (or) damage to the product.

Assembly should be carried out exactly according to the instructions, otherwise a safety risk can occur if incorrectly assembled.







The fittings pack contains SMALL ITEMS which should be KEPT AWAY FROM YOUNG CHILDREN. A full checklist of components is given in this leaflet. If any components are missing, please contact the retailer from whom you bought this product.

Read this leaflet in full before use.

PLEASE KEEP THESE INSTRUCTIONS FOR FUTURE REFERENCE

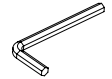
Ercol Furniture Ltd, Summerleys Road, Princes Risborough, Buckinghamshire. HP27 9PX ercol.com

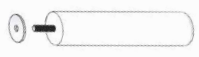
Fittings and parts checklist

A	2 x Leg assembly	
B	8 x 60mm Connector bolts	
C	1 x Allen key	
D	4 x Front brackets	
E	16 x M5x20 Pan head screws	
F	1 x Centre foot (for large & grand sofas only)	
G	5 x Felt pads	

Step by step assembly instructions

1. Carefully place the sofa, chair or footstool on its back onto a clean soft surface.
2. Unscrew the transport legs (by hand) and discard.

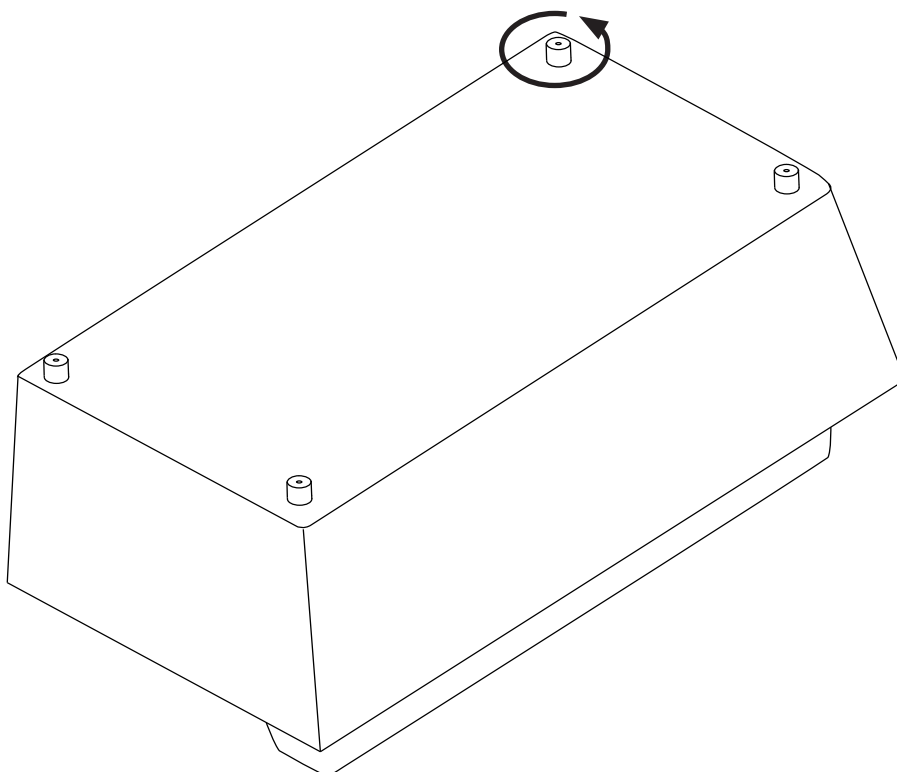

3. Fix bracket (D) to the pilot hole located on the side of the leg assembly (A) using the M5x20 Pan head screws (E).

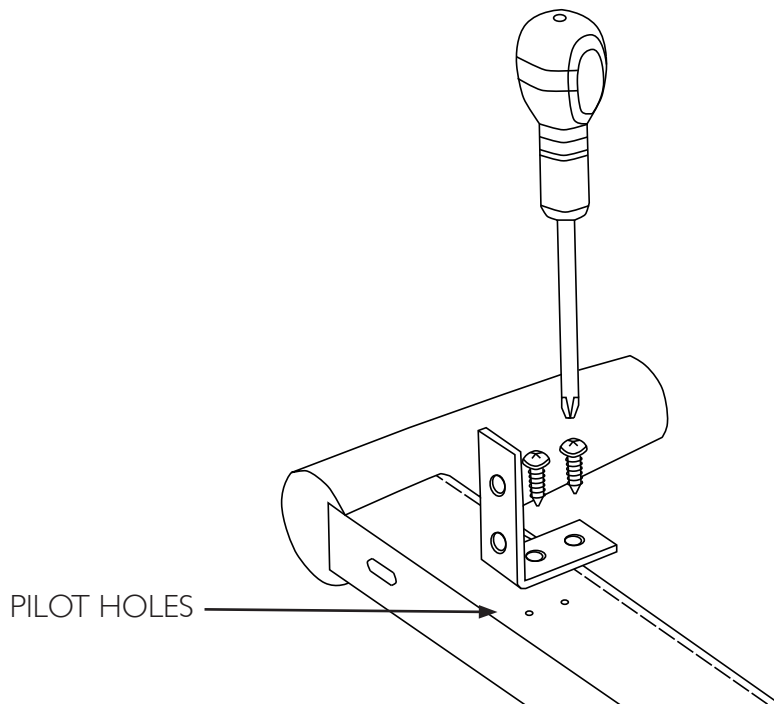

4. Using the 8x60mm Connector bolts (B) screw the leg assembly (A) into the base of the sofa using the allen key (C). Repeat on both sides.

We recommend that all four connector bolts are located and partially tightened together to ensure their alignment is accurate, then fully tighten.

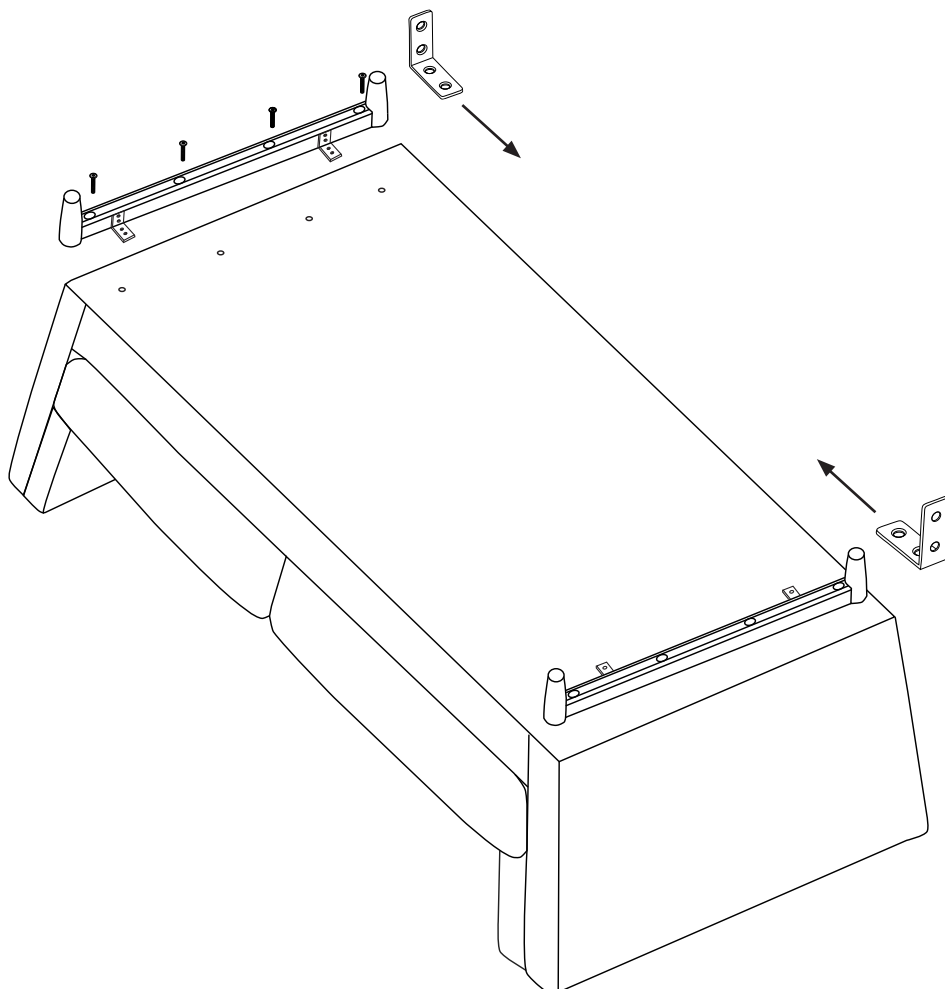

5. Fix the brackets (D) using x8 M5x20 Pan head screws (E) into the base of the sofa using a screwdriver.

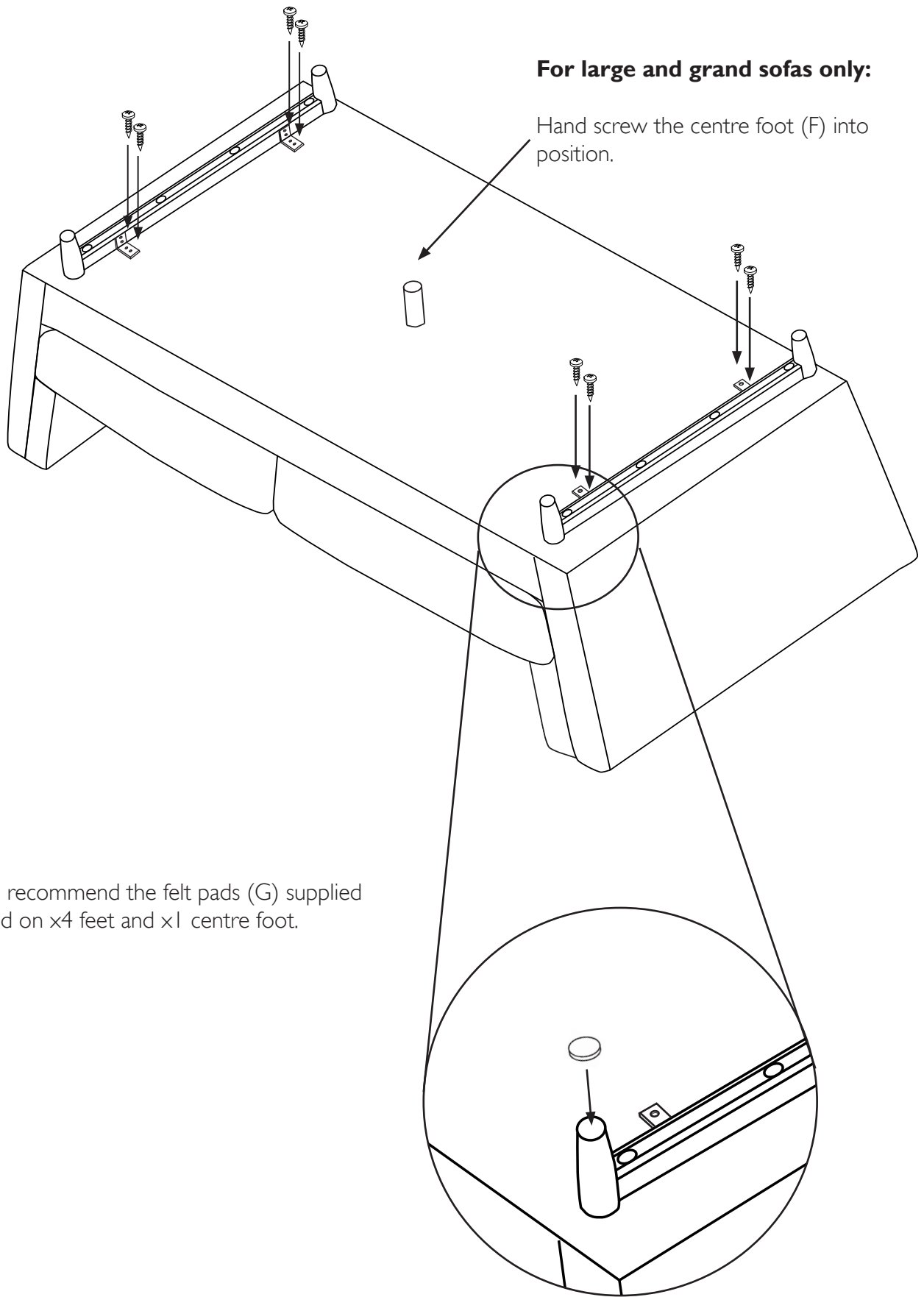

5a. We recommend the felt pads (G) supplied are used on x4 feet and x1 centre foot.

Customer Care

Wood Furniture

Wood displays different grain patterns depending on which way it is cut - for example, the 'medullary ray' which can appear on oak furniture is a mark of good quality timber - these are characteristics of the natural beauty of the wood. All timber surfaces will change colour and mellow over time. New furniture will initially vary in shade from items that have been previously purchased.

How to care for your wood furniture

Furniture with a hard lacquer, wax polish or painted surface should be dusted with a dry cloth. When using the surface for serving food and drinks it is best to use protective mats and coasters. Spillages should be wiped up as soon as possible. Spray polishes should be avoided as they can contain silicones which may spoil the furniture's surface by building up over time. Use of cleaning materials containing abrasive compounds, acidic or caustic reagents and any bleaches containing oxidising reagents should be avoided as prolonged use may damage the lacquer surface. If sticky marks occur on the surface they can be removed with a dilute solution of warm soapy water. The area should be rubbed lightly and then completely dried immediately afterwards, before replacing any mats etc. Our furniture will endure most temperatures in the home but it is best to avoid placing furniture next to heat sources such as radiators or fires. Be particularly careful with solid wood as the lack of humidity caused by central heating can cause damage, such as warping.

Safety Instructions

Never drag furniture when moving it, always lift it. Take care when handling or moving the furniture as careless handling may cause damage or injury. No liability will be accepted for damage or injury caused by incorrectly installed furniture.

Fabric Care

Every effort is made to keep colours consistent between batches, but fabric manufacturers cannot guarantee exact matching. All fabrics will fade in sunlight, to prolong the life of the fabric do not place it close to a heat source or in direct sunlight. Plump up cushions after use, especially fibre or feather cushions. If the cushions are reversible turn them at least once a week to minimise wear and maintain their appearance. To prevent dust and dirt accelerating wear, gently vacuum upholstery once a week or use a soft brush. For complete cleaning we recommend a specialist cleaning in situ. Accidental spills and stains should be treated as soon as possible, except mud which should be left to dry and then brushed off. Remove any solids, then blot up as much liquid as possible with white paper towel or a clean cloth. We recommend professional dry cleaning but some action can limit damage.

Leather Care

As leather is a natural product, each hide will have its own individual characteristics - grain pattern, texture and colour will vary from hide to hide and even within the same hide. All of which contribute to the natural beauty and softness of the hides. Keep your leather furniture at least 40cm away from any heat source and if possible avoid exposure to direct sunlight preventing colour fading, dehydration and cracks. Leather furniture in a normal domestic environment should require little attention. Cleaning should only be done when necessary. We advise that the leather should be regularly dusted. At least twice a year the surface should be wiped over with a damp cloth, with special attention paid to crevices where dust and dirt could be a cause of hidden wear. Do not apply any chemical or abrasive products. If you have a spillage on your leather furniture, act immediately and dab off any excess liquids and solids, then contact a specialist leather cleaning company.

PLEASE KEEP THESE INSTRUCTIONS FOR FUTURE REFERENCE

Ercol Furniture Ltd, Summerleys Road, Princes Risborough, Buckinghamshire. HP27 9PX ercol.com